

Customer Information Sheet

DRAWING No.: H2170-XX - H2174-XX

SHEET 2 OF 2

IF IN DOUBT - ASK

Ⓒ

NOT TO SCALE

THIRD ANGLE PROJECTION

ALL DIMENSIONS IN mm

ORDER CODE:

H217X-XX

PART No: _____
SEE TABLE

FINISH: _____
01 = TIN
05 = GOLD

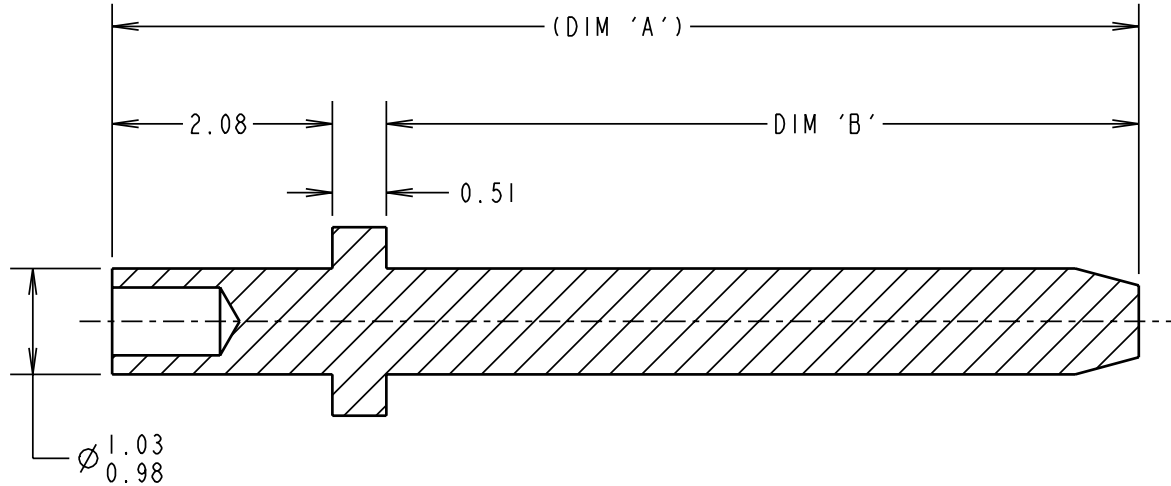

SECTION X-X

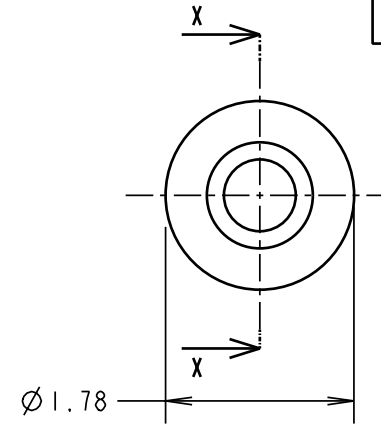

- NOTES:
1. RECOMMENDED MOUNTING HOLE SIZE = $\varnothing 1.04-1.14$ mm.
 2. RECOMMENDED PANEL THICKNESS = 1.6mm.
 3. ALL TOLERANCES ARE ± 0.13 UNLESS OTHERWISE STATED.

PART No.	(DIM 'A')	DIM 'B'	PUNCH & DIE TOOL No.
H2170-XX	(15.29)	12.70	Z2170-00
H2171-XX	(21.64)	19.05	Z2171-00
H2172-XX	(27.99)	25.40	Z2172-00
H2173-XX	(10.21)	7.62	Z2173-00
H2174-XX	(6.40)	3.81	Z2174-00

JAE	5	25.03.03	7380
NAME	ISS.	DATE	C/NOTE
APPROVED: P. COLLINS			
CHECKED: W. J. BOURNE			
DRAWN: J. PHILIPSON			
CUSTOMER REF.:			
ASSEMBLY DRG:			

HARWIN

THIS DRAWING AND ANY INFORMATION OR DESCRIPTIVE MATTER SET OUT HEREON ARE CONFIDENTIAL AND COPYRIGHT PROPERTY OF THE HARWIN GROUP AND MUST NOT BE DISCLOSED, LOANED, COPIED OR USED FOR MANUFACTURING, TENDERING OR FOR ANY OTHER PURPOSE WITHOUT THEIR WRITTEN PERMISSION.

TOLERANCES
X. = ± 1 mm
X.X = ± 0.25 mm
X.XX = ± 0.10 mm
X.XXX = ± 0.01 mm
ANGLES = $\pm 5^\circ$
UNLESS STATED

MATERIAL:
BRASS CW603N TO
BS EN 12164 (CuZn36Pb3)

FINISH: SEE ABOVE

S/AREA: mm²

TITLE:
TERMINAL PIN

DRAWING NUMBER:
H2170-XX - H2174-XX

SHT
2 OF 2

HARWIN INC U.S.A. TEL: (812) 542 2546 FAX: (812) 542 2541	HARWIN PLC U.K. TEL: 023 9237 0451 FAX: 023 9231 4590	HARWIN PTE SINGAPORE TEL: 65 6779 4909 FAX: 65 6779 3868
--------------------------------------------------------------------	----------------------------------------------------------------	-------------------------------------------------------------------