

# Customer Information Sheet

DRAWING No.: M22-253XXXX

SHEET 2 OF 2

IF IN DOUBT - ASK

(C)

NOT TO SCALE

THIRD ANGLE PROJECTION

ALL DIMENSIONS IN mm

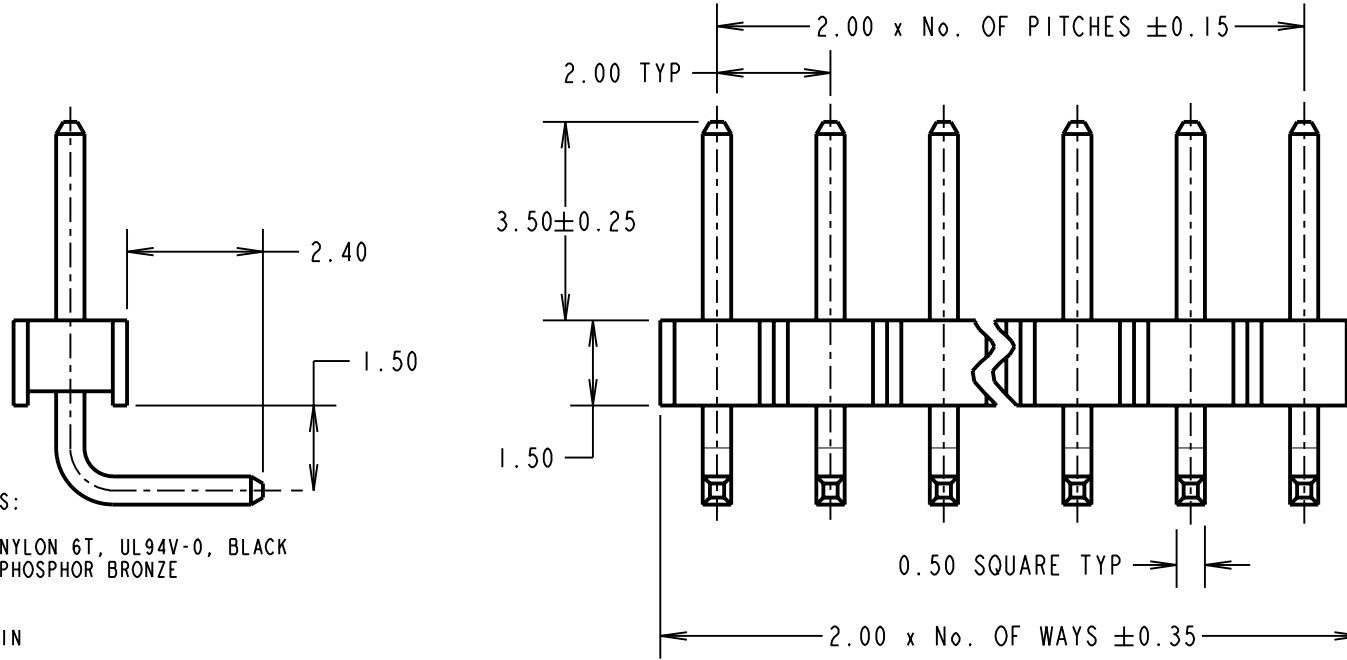

ORDER CODE:

**M22-253XXXX**

No. OF WAYS \_\_\_\_\_  
02 - 50

FINISH \_\_\_\_\_  
05 = GOLD  
46 = 100% TIN

**SPECIFICATIONS:**

**MATERIAL:**

MOULDING = NYLON 6T, UL94V-0, BLACK  
CONTACTS = PHOSPHOR BRONZE

**FINISH:**

05 = GOLD  
46 = 100% TIN

**ELECTRICAL:**

CURRENT RATING = 1A  
VOLTAGE PROOF = 650V AC  
CONTACT RESISTANCE:

INITIAL = 15 mΩ MAX (GOLD), 20 mΩ MAX (TIN)  
AFTER CONDITIONING = 20 mΩ MAX (GOLD), 30 mΩ MAX (TIN)

**INSULATION RESISTANCE:**

INITIAL = 1,000 MΩ MIN  
AFTER CONDITIONING = 100 MΩ MIN

**MECHANICAL:**

DURABILITY = 300 OPERATIONS (GOLD), 50 OPERATIONS (TIN)  
INSERTION FORCE = 2N MAX  
WITHDRAWAL FORCE = 0.3N MIN

**ENVIRONMENTAL:**

TEMPERATURE RANGE = -55°C TO +105°C

**PACKING:**

BAG

FOR COMPLETE SPECIFICATION, SEE  
COMPONENT SPECIFICATION C018XX (LATEST ISSUE)

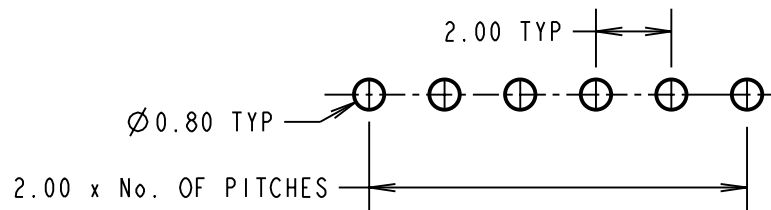

RECOMMENDED PCB LAYOUT

**NOTES:**

1. ALL TOLERANCES ARE ±0.20 UNLESS OTHERWISE STATED.

CP	6	14.09.09	10298
NAME	ISS.	DATE	C/NOTE
APPROVED: C.PENROSE			
CHECKED: R.ADDE			
DRAWN: W. J. BOURNE			
CUSTOMER REF.:			
ASSEMBLY DRG:			

**HARWIN**

HARWIN USA TEL: 603 893 5376 FAX: 603 893 5396 mis@harwin.com	HARWIN Europe (UK) TEL: 023 9231 4545 FAX: 023 9231 4590 mis@harwin.co.uk	HARWIN Asia TEL: +65 6 779 4909 FAX: +65 6 779 3868 mis@harwin.com.sg
--	--	--

THIS DRAWING AND ANY INFORMATION OR DESCRIPTIVE MATTER SET OUT HEREON ARE CONFIDENTIAL AND COPYRIGHT PROPERTY OF THE HARWIN GROUP AND MUST NOT BE DISCLOSED, LOANED, COPIED OR USED FOR MANUFACTURING, TENDERING OR FOR ANY OTHER PURPOSE WITHOUT THEIR WRITTEN PERMISSION.

**TOLERANCES**  
~~X = ±1mm~~  
~~X.X = ±0.25mm~~  
~~X.XX = ±0.10mm~~  
~~X.XXX = ±0.01mm~~  
ANGLES = ±5°  
UNLESS STATED

**MATERIAL:**  
SEE ABOVE  
**FINISH:** SEE ABOVE  
**S/AREA:** mm<sup>2</sup>

**TITLE:**  
2.00mm PITCH SIL HORIZONTAL  
PC TAIL PIN HEADER ASSEMBLY  
**DRAWING NUMBER:**  
**M22-253XXXX**  
SHT 2 OF 2